



LANDSLIDE CDMA-FEMTOCELL PERFORMANCE TEST SYSTEM



LTE is a trade mark of ETSI

July 2009
Rev D

Components of Landslide system

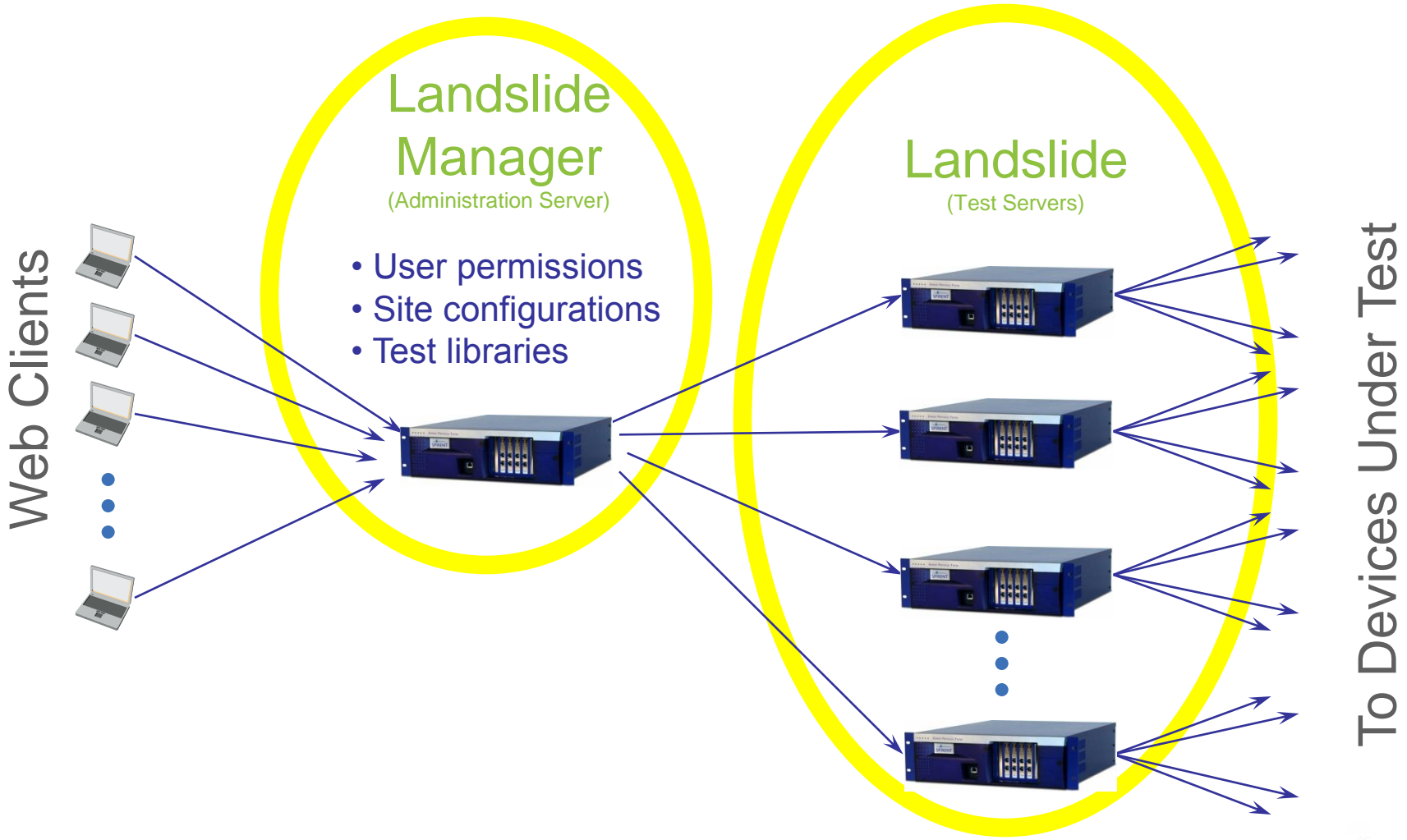

Landslide Applications/Features

- LTE_™ Performance Testing
- WiMax Performance Testing
- UMTS Performance Testing
- GPRS Performance Testing
- CDMA Performance Testing
- Mobility over IPv4/IPv6
- AAA Performance Testing (RADIUS and Diameter)
- AAA Server Emulation
- Advanced Data with IPSec
- L2TP VPN Gateway
- Charging Gateway Function Emulator
- IMS Security and Policy Testing
- eHRPD
- Femtocell

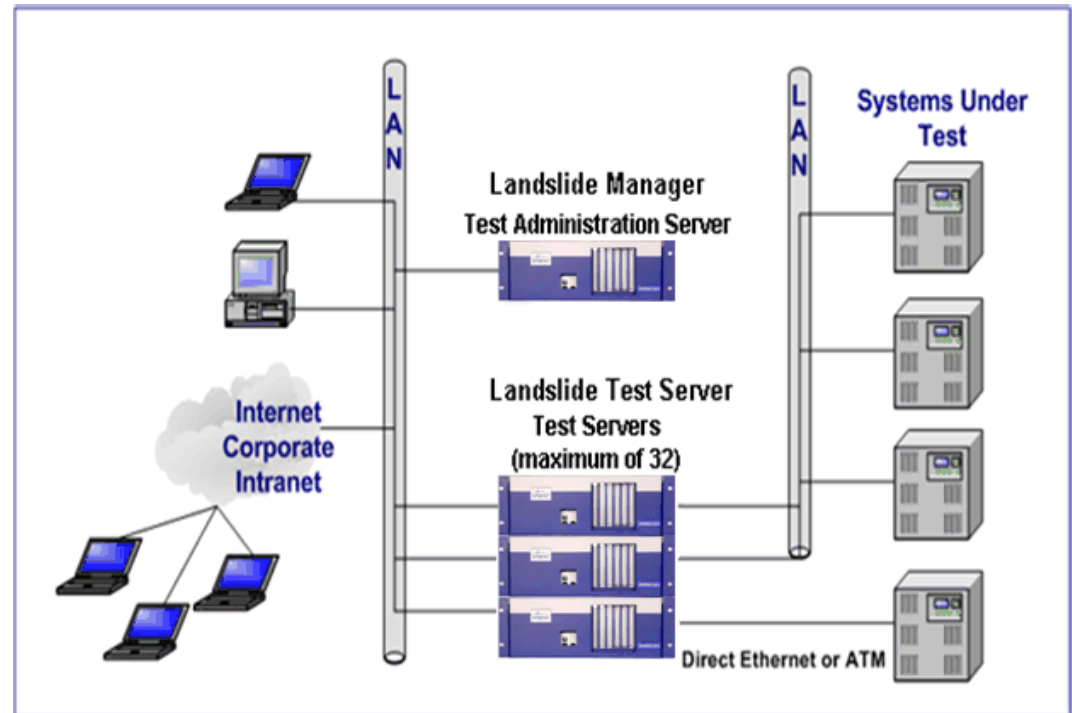

- CDMA/WI-FI Convergence (PDFI)
- GPRS/WI-FI Convergence (PDG)
- DCCA - performance testing and server emulation
- PCRF - performance testing and server emulation

Network In a Box

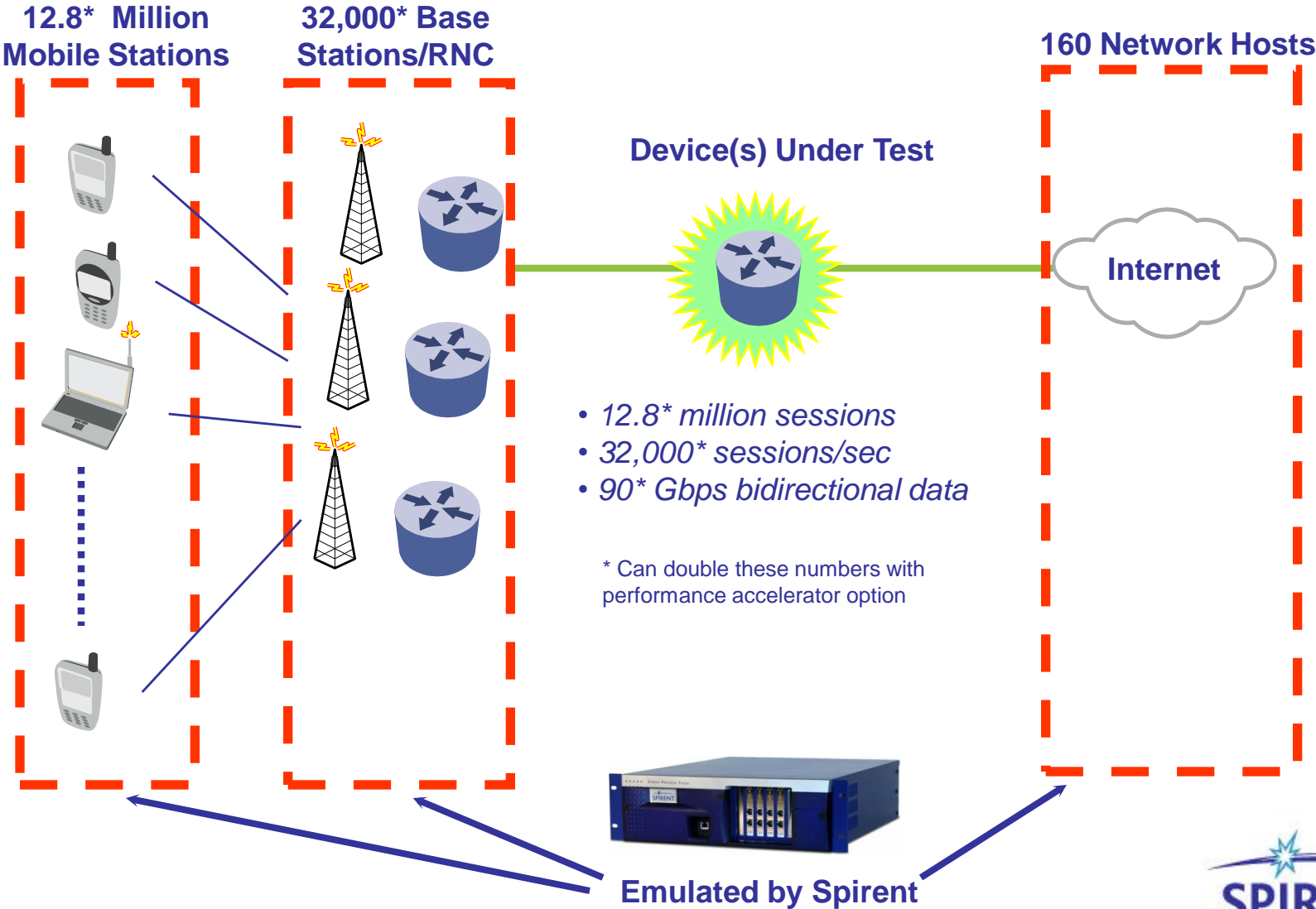

Complete Network Coverage

Emulate

- AAA Diameter Servers
- AAA Radius Servers
- GGSN
- SGSN
- Foreign Agent
- Home Agent
- PDSN
- Base Station Controllers
- LTE™ Clients
- UMTS Clients
- GPRS Clients
- CDMA Clients
- WiMAX Clients
- WiFi Clients
- AAA Clients
- Mobile IP Clients
- Internet/Network Host
- IPSec Clients
- PCRF
- Femtocell

Test

- Foreign Agent
- Home Agent
- Corresponding Node
- LTE™ MME
- GGSN
- SGSN
- Security Gateways
- PDIF/PDG
- End-to-end Systems
- AAA Diameter Servers
- AAA Radius Servers
- L2TP VPN Gateway
- Application Servers
- Content Billing Systems
- CDR Records
- ASN/CSN
- PCRF
- eHRPD HSGW
- FNG





CDMA FEMTOCELL NETWORK TESTING

CDMA Femtocell Network Testing

- # Test scalability and performance capabilities of FNGs
- # Control Plane and Bearer Plane
- # Simple IP
- # IPv4 and IPv6
- # Open RP, PPP
- # Emulators:
 - # MN
 - # Femtocell
 - # Security GW/FNG

FNG Nodal Testing

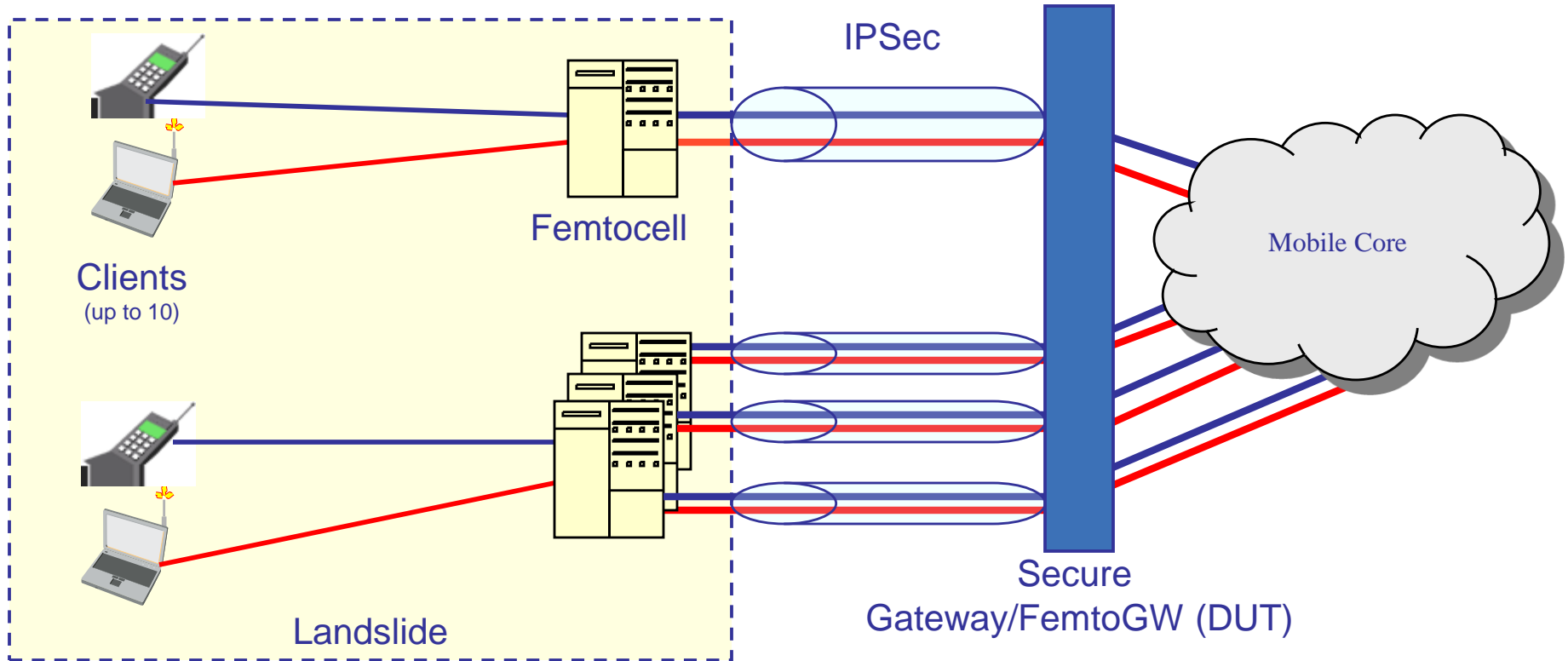

- Emulate femtocell(s) and clients behind them
- Single IPSec tunnel between emulated femtocell and secure gateway
- Up to 10 clients behind femtocell
- Traffic for all clients flows over the one femtocell IPSec tunnel
(Note: SeGW and FemtoGW may be different devices)

Landslide CDMA Performance Capabilities

- Up to 1000 MN activations per second
- Up to 1000 Femtocell activations per second (without IPsec)
- Up to 200 Femtocell activations per second (with IPsec)
- Up to 100,000 emulated Femtocells
- Up to 10 emulated MN per Femtocell
- Up to 100,000 emulated MN
- Numbers can be doubled with performance accelerator feature

Performance based on a single
Landslide server



TEST METHODOLOGY

Performance Testing

- Key Test Types
 - Capacity Test*
 - Mobility Tests
 - Session Loading*
 - Session Loading with Mobility

* Test Types Supported by CDMA Femtocell

- ⊞ Data flows can be included in all test types.
- ⊞ Test types can be combined and complex traffic patterns can be simulated using automation control.

Test Methodology - Capacity Test

- A key measurement of a DUT is its capacity for simultaneous sessions
- The Landslide begins establishing sessions at a specified rate
- When the maximum is reached all subsequent sessions fail
- Established sessions are kept active for the specified period or until stopped
- Finally sessions are deactivated at a specified rate
- Help->Test Activities->Capacity Test
->About the Capacity Test

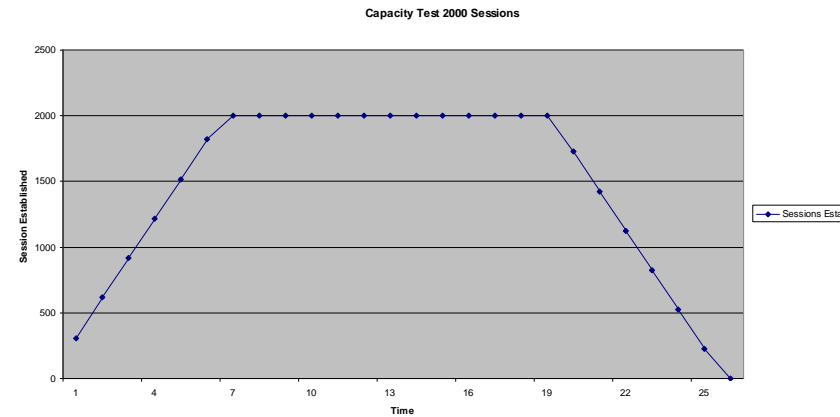

Test Methodology - Session Loading Test

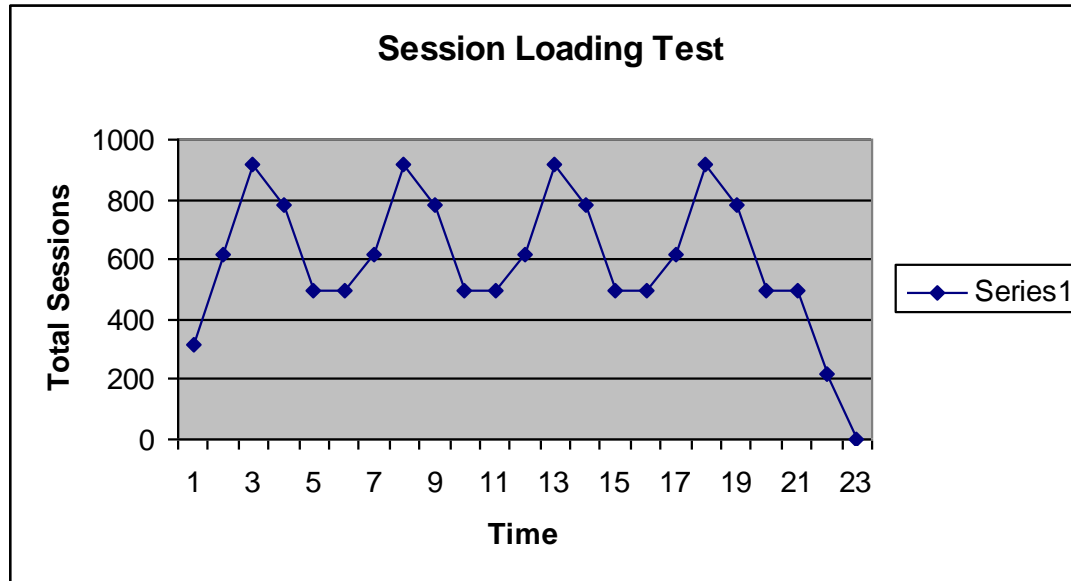

- A key measurement of a DUT is its ability to process real world activity for a long period of time
- Session loading emulates multiple simultaneous real world events
 - Session activations
 - Session deactivations
 - Data transactions of various types
 - Handovers
- [Help->Test Activities->Session Loading->About the Session Loading Test](#)

Test Methodology -Continuous Data

- Data packets of a user defined flow(s) are transported over the sessions.
- User may select pre-configured data flows from the basic library or build custom flows using the powerful data flow editor.
- Capacity - transmission can begin as each session is established or after all sessions are successfully established.
- Session Loading - transmission begins as each session is established.
- Protocols flows currently supported include: Ping (ICMP), RAW, SCTP, UDP, TCP, HTTP, FTP, WAP 1.X, WAP 2.0, SMTP, POP3, IMAP, RSTP, RTP, SIP, Wireless Village and Custom built or imported

Combined Complex Test Cases

Capacity
Mobility



+

Session Loading

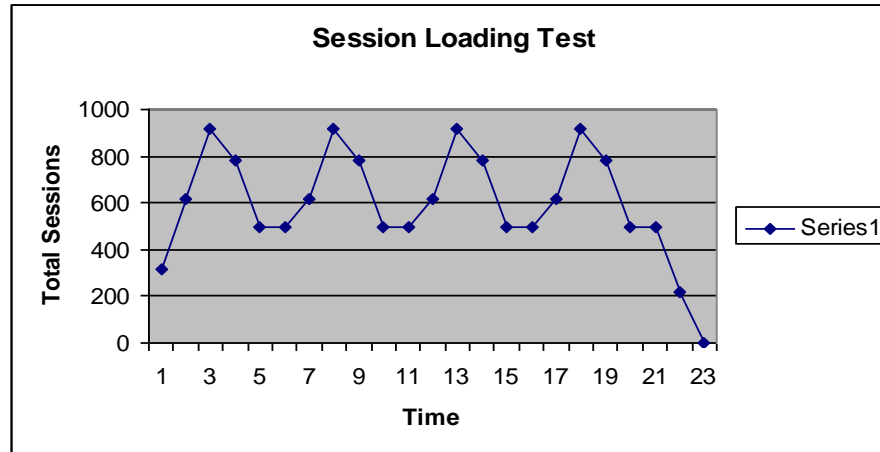

+

Data Traffic
Generation

Real World Network Modeling

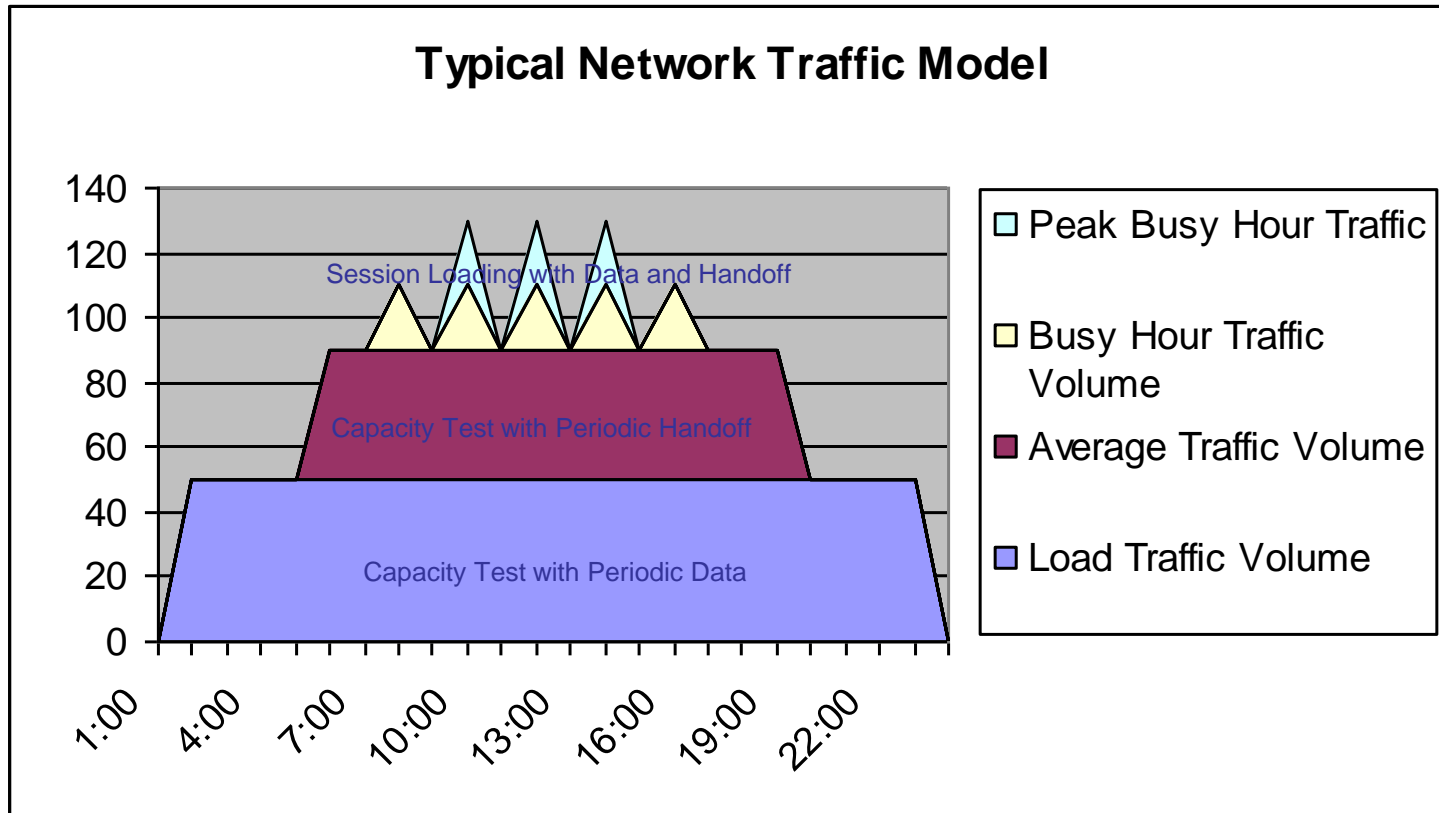

- Create real-world traffic patterns in lab
- Need wide range of control plane and data plane profiles
- Test with expect and worst-case use scenarios



Thank You!